



Series WX1YZ/4



SET ~ 3

प्रश्न-पत्र कोड
Q.P. Code

430/4/3

रोल नं.
Roll No.

--	--	--	--	--	--	--

परीक्षार्थी प्रश्न-पत्र कोड को उत्तर-पुस्तिका के मुख-पृष्ठ पर अवश्य लिखें।
Candidates must write the Q.P. Code on the title page of the answer-book.

गणित (बुनियादी)
MATHEMATICS (BASIC)
#

निर्धारित समय : 3 घण्टे
Time allowed : 3 hours

अधिकतम अंक : 80
Maximum Marks : 80

नोट / NOTE :

- (i) कृपया जाँच कर लें कि इस प्रश्न-पत्र में मुद्रित पृष्ठ 15 हैं।
Please check that this question paper contains 15 printed pages.
- (ii) प्रश्न-पत्र में दाहिने हाथ की ओर दिए गए प्रश्न-पत्र कोड को छात्र उत्तर-पुस्तिका के मुख-पृष्ठ पर लिखें।
Q. P. Code given on the right hand side of the question paper should be written on the title page of the answer-book by the candidate.
- (iii) कृपया जाँच कर लें कि इस प्रश्न-पत्र में 38 प्रश्न हैं।
Please check that this question paper contains 38 questions.
- (iv) कृपया प्रश्न का उत्तर लिखना शुरू करने से पहले, उत्तर-पुस्तिका में प्रश्न का क्रमांक अवश्य लिखें।
Please write down the Serial Number of the question in the answer-book before attempting it.
- (v) इस प्रश्न-पत्र को पढ़ने के लिए 15 मिनट का समय दिया गया है। प्रश्न-पत्र का वितरण पूर्वाह्न में 10.15 बजे किया जाएगा। 10.15 बजे से 10.30 बजे तक छात्र केवल प्रश्न-पत्र को पढ़ेंगे और इस अवधि के दौरान वे उत्तर-पुस्तिका पर कोई उत्तर नहीं लिखेंगे।
15 minute time has been allotted to read this question paper. The question paper will be distributed at 10.15 a.m. From 10.15 a.m. to 10.30 a.m., the students will read the question paper only and will not write any answer on the answer-book during this period.

430/4/3 ~~~~

1

[P.T.O.]





सामान्य निर्देश :

निम्नलिखित निर्देशों को बहुत सावधानी से पढ़िए और उनका पालन कीजिए :

1. इस प्रश्न-पत्र में 38 प्रश्न हैं। सभी प्रश्न अनिवार्य हैं।
2. प्रश्न-पत्र पाँच खण्डों में विभाजित है - खण्ड क, ख, ग, घ तथा ङ।
3. खण्ड क में प्रश्न संख्या 1 से 18 तक बहुविकल्पीय तथा प्रश्न संख्या 19 एवं 20 अभिकथन एवं कारण आधारित एक-एक अंक के प्रश्न हैं।
4. खण्ड ख में प्रश्न संख्या 21 से 25 तक अति लघु-उत्तरीय (VSA) प्रकार के दो-दो अंकों के प्रश्न हैं।
5. खण्ड ग में प्रश्न संख्या 26 से 31 तक लघु-उत्तरीय (SA) प्रकार के तीन-तीन अंकों के प्रश्न हैं।
6. खण्ड घ में प्रश्न संख्या 32 से 35 तक दीर्घ-उत्तरीय (LA) प्रकार के पाँच-पाँच अंकों के प्रश्न हैं।
7. खण्ड ङ में प्रश्न संख्या 36 से 38 स्रोत/प्रकरण इकाई आधारित चार-चार अंकों के प्रश्न हैं। आंतरिक विकल्प दो-दो अंकों के प्रश्न में दिया गया है।
8. प्रश्न-पत्र में समग्र विकल्प नहीं दिया गया है। यद्यपि, खण्ड ख के 2 प्रश्नों में, खण्ड ग के 2 प्रश्नों में, खण्ड घ के 2 प्रश्नों में तथा खण्ड ङ के 3 प्रश्नों में आंतरिक विकल्प का प्रावधान दिया गया है।
9. जहाँ आवश्यक हो स्वच्छ आकृतियाँ बनाएं। यदि आवश्यक हो तो $\pi = 22/7$ लें।
10. कैलकुलेटर का उपयोग वर्जित है।

खण्ड - क

खण्ड - क में बहुविकल्पीय प्रकार के प्रश्न हैं और प्रत्येक प्रश्न का 1 अंक है।

1. k का मान जिसके लिए समीकरण $3x - y + 8 = 0$ और $6x - ky + 16 = 0$ द्वारा निरूपित रेखाएँ संपाती हैं, है : 1
 (a) $\frac{1}{2}$ (b) $-\frac{1}{2}$ (c) 2 (d) -2
2. त्रिज्या 5.2 सेमी. के एक वृत्त पर AB तथा CD दो समान्तर स्पर्श रेखाएँ हैं। इन स्पर्श रेखाओं के बीच की दूरी कितनी है ? 1
 (a) 5.2 सेमी. (b) 10.4 सेमी.
 (c) 20.8 सेमी. (d) दूरी नहीं निकाली जा सकती है
3. द्विघात बहुपदों, जिनके शून्यांक -3 और 4 हों, की संख्या है : 1
 (a) 1 (b) 2 (c) 3 (d) 3 से अधिक
4. यदि एक वृत्त का परिमाप और क्षेत्रफल संख्यात्मक रूप से बराबर है, तो उस वृत्त की त्रिज्या है : 1
 (a) 2 मात्रक (b) π मात्रक (c) 4 मात्रक (d) 2π मात्रक
5. एक द्विघात समीकरण, जिसका एक मूल 2 और मूलों का योग शून्य है, है : 1
 (a) $x^2 + 4 = 0$ (b) $x^2 - 2 = 0$ (c) $4x^2 - 1 = 0$ (d) $x^2 - 4 = 0$
6. निम्न में कौन, द्विघात समीकरण नहीं है ? 1
 (a) $2(x-1)^2 = 4x^2 - 2x + 1$ (b) $2x - x^2 = x^2 + 5$
 (c) $(\sqrt{2}x + \sqrt{3})^2 + x^2 = 3x^2 - 5x$ (d) $(x^2 + 2x)^2 = x^4 + 3 + 4x^3$

430/4/3

2





General Instructions :

Read the following instructions carefully and follow them :

1. This question paper contains **38** questions. **All** questions are compulsory.
2. Question paper is divided into **FIVE** sections - Section **A, B, C, D** and **E**.
3. In section **A**, question number **1** to **18** are multiple choice questions (MCQs) and question number **19** and **20** are Assertion - Reason based questions of 1 mark each.
4. In section **B**, question number **21** to **25** are very short answer (VSA) type questions of 2 marks each.
5. In section **C**, question number **26** to **31** are short answer (SA) type questions carrying 3 marks each.
6. In section **D**, question number **32** to **35** are long answer (LA) type questions carrying 5 marks each.
7. In section **E**, question number **36** to **38** are **case based integrated units** of assessment questions carrying 4 marks each. Internal choice is provided in 2 marks question in each case study.
8. There is no overall choice. However, an internal choice has been provided in 2 questions in Section **B**, 2 questions in Section **C**, 2 questions in Section **D** and 3 questions in Section **E**.
9. Draw neat figures wherever required. Take $\pi = 22/7$ wherever required if not stated.
10. Use of calculators is **not allowed**.

SECTION - A

Section - A consists of Multiple Choice type questions of 1 mark each.

1. The value of k for which the equations $3x - y + 8 = 0$ and $6x - ky + 16 = 0$ represent coincident lines is : 1
 (a) $\frac{1}{2}$ (b) $-\frac{1}{2}$ (c) 2 (d) -2
2. A circle of radius 5.2 cm has two tangents AB and CD parallel to each other. What is the distance between the two tangents ? 1
 (a) 5.2 cm (b) 10.4 cm (c) 20.8 cm (d) can't find
3. The number of polynomials having zeroes - 3 and 4 is : 1
 (a) 1 (b) 2 (c) 3 (d) more than 3
4. If the perimeter and the area of a circle are numerically equal, then the radius of the circle is : 1
 (a) 2 units (b) π units (c) 4 units (d) 2π units
5. A quadratic equation whose one root is 2 and the sum of whose roots is zero, is : 1
 (a) $x^2 + 4 = 0$ (b) $x^2 - 2 = 0$ (c) $4x^2 - 1 = 0$ (d) $x^2 - 4 = 0$
6. Which of the following is **not** a quadratic equation ? 1
 (a) $2(x-1)^2 = 4x^2 - 2x + 1$ (b) $2x - x^2 = x^2 + 5$
 (c) $(\sqrt{2}x + \sqrt{3})^2 + x^2 = 3x^2 - 5x$ (d) $(x^2 + 2x)^2 = x^4 + 3 + 4x^3$





7. एक वृत्त पर स्थित एक बिंदु से वृत्त पर कितनी स्पर्श रेखाएँ खींची जा सकती हैं ? 1
(a) एक (b) दो (c) अनेक (d) शून्य
8. निम्न में कौनसी संख्या एक घटना की प्रायिकता नहीं होती है ? 1
(a) 0.1 (b) $\frac{5}{3}$ (c) 3% (d) $\frac{1}{3}$
9. 30 मी. ऊँची मीनार के पाद-बिंदु से 30 मी. की दूरी पर स्थित एक बिंदु से मीनार के शिखर का उन्नयन कोण है : 1
(a) 30° (b) 45° (c) 60° (d) 90°
10. संख्याओं 2, 3, 3, 4, 5, 4, 4, 5, 3, 4, 2, 6, 7 का बहुलक है : 1
(a) 2 (b) 3 (c) 4 (d) 5
11. यदि $x - y = 1$, $x + ky = 5$ रैखिक समीकरण युग्म का अद्वितीय हल $x = 2, y = 1$ है, तो k का मान है : 1
(a) -2 (b) -3 (c) 3 (d) 4
12. 70 और 40 के लिए (HCF \times LCM) बराबर है : 1
(a) 10 (b) 280 (c) 2800 (d) 70
13. संख्या $(5 - 3\sqrt{5} + \sqrt{5})$ एक : 1
(a) पूर्णांक है (b) परिमेय संख्या है (c) अपरिमेय संख्या है (d) पूर्ण संख्या है
14. यदि बहुपद $p(x) = x^2 + 5x + 6$ है, तो $p(-2)$ का मान है : 1
(a) 20 (b) 0 (c) -8 (d) 8
15. यदि $\triangle ABC \sim \triangle DEF$ है और $\angle A = 47^\circ$, $\angle E = 83^\circ$ है, तो $\angle C$ बराबर है : 1
(a) 47° (b) 50° (c) 83° (d) 130°
16. 52 ताश के पत्तों की अच्छी प्रकार से फेंटी गई एक गड्डी में से एक पत्ता यादृच्छया निकाला जाता है। इस पत्ते के लाल बेगम होने की प्रायिकता क्या है ? 1
(a) $\frac{1}{52}$ (b) $\frac{1}{26}$ (c) $\frac{1}{13}$ (d) $\frac{12}{13}$
17. त्रिज्या 7 सेमी. वाले वृत्त के उस चाप की लम्बाई, जो वृत्त के केंद्र पर 90° का कोण अंतरित करता है, कितनी है ? 1
(a) 22 सेमी. (b) 11 सेमी. (c) $\frac{77}{2}$ सेमी. (d) $\frac{11}{2}$ सेमी.
18. $(3 \sin^2 30^\circ - 4 \cos^2 60^\circ)$ बराबर है : 1
(a) $\frac{5}{4}$ (b) $-\frac{3}{4}$ (c) $-\frac{1}{4}$ (d) $-\frac{9}{4}$





7. How many tangents can be drawn to a circle from a point on it ? 1
(a) One (b) Two (c) Infinite (d) Zero
8. Which of the following **cannot** be the probability of an event ? 1
(a) 0.1 (b) $\frac{5}{3}$ (c) 3% (d) $\frac{1}{3}$
9. The angle of elevation of the top of a 30 m high tower at a point 30 m away from the base of the tower is : 1
(a) 30° (b) 45° (c) 60° (d) 90°
10. The mode of the numbers 2, 3, 3, 4, 5, 4, 4, 5, 3, 4, 2, 6, 7 is : 1
(a) 2 (b) 3 (c) 4 (d) 5
11. If the pair of linear equations $x - y = 1$, $x + ky = 5$ has a unique solution $x = 2$, $y = 1$, then the value of k is : 1
(a) -2 (b) -3 (c) 3 (d) 4
12. (HCF \times LCM) for the numbers 70 and 40 is : 1
(a) 10 (b) 280 (c) 2800 (d) 70
13. The number $(5 - 3\sqrt{5} + \sqrt{5})$ is : 1
(a) an integer (b) a rational number
(c) an irrational number (d) a whole number
14. If $p(x) = x^2 + 5x + 6$, then $p(-2)$ is : 1
(a) 20 (b) 0 (c) -8 (d) 8
15. If $\triangle ABC \sim \triangle DEF$ and $\angle A = 47^\circ$, $\angle E = 83^\circ$, then $\angle C$ is equal : 1
(a) 47° (b) 50° (c) 83° (d) 130°
16. From a well-shuffled deck of 52 playing cards, a card is drawn at random. What is the probability of getting a red queen ? 1
(a) $\frac{1}{52}$ (b) $\frac{1}{26}$ (c) $\frac{1}{13}$ (d) $\frac{12}{13}$
17. What is the length of arc of a circle of radius 7 cm which subtends an angle of 90° at the centre of the circle ? 1
(a) 22 cm (b) 11 cm (c) $\frac{77}{2}$ cm (d) $\frac{11}{2}$ cm
18. $(3 \sin^2 30^\circ - 4 \cos^2 60^\circ)$ is equal to : 1
(a) $\frac{5}{4}$ (b) $-\frac{3}{4}$ (c) $-\frac{1}{4}$ (d) $-\frac{9}{4}$





(अभिकथन – तर्क प्रकार के प्रश्न)

प्रश्न संख्या 19 तथा 20 में एक अभिकथन (A) के बाद एक तर्क-कथन (R) दिया है। निम्न में से सही विकल्प चुनिए :

- (a) अभिकथन (A) तथा तर्क (R) दोनों सत्य हैं। तर्क (R), अभिकथन (A) की पूरी व्याख्या करता है।
- (b) अभिकथन (A) तथा तर्क (R) दोनों सत्य हैं। तर्क (R), अभिकथन (A) की व्याख्या नहीं करता है।
- (c) अभिकथन (A) सत्य है परन्तु तर्क (R) असत्य है।
- (d) अभिकथन (A) असत्य है जबकि तर्क (R) सत्य है।

19. अभिकथन (A) : वृत्त के किसी बिंदु पर स्पर्श रेखा स्पर्श बिंदु से जाने वाली त्रिज्या पर लंब होती है।

तर्क (R) : एक वृत्त के बाहर स्थित एक बिंदु से उस पर खींची गई स्पर्श रेखाओं की लम्बाई एकसमान होती हैं। 1

20. अभिकथन (A) : यदि द्विघात समीकरण $4x^2 - 10x + (k - 4) = 0$ का एक मूल दूसरे मूल का व्युत्क्रम है, तो k का मान 8 होगा।

तर्क (R) : द्विघात समीकरण $x^2 - x + 1 = 0$ के मूल वास्तविक हैं। 1

खण्ड – ख

खण्ड – ख में अति लघु-उत्तर (VSA) प्रकार के प्रश्न हैं और प्रत्येक प्रश्न के 2 अंक हैं।

21. (A) द्विघात समीकरण $3x^2 - 2x + \frac{1}{3} = 0$ का विविक्तकर ज्ञात कीजिए और फिर इसके मूलों की प्रकृति ज्ञात कीजिए। 2

अथवा

(B) द्विघात समीकरण $x^2 - x - 2 = 0$ के मूल ज्ञात कीजिए। 2

22. बगल में बनी आकृति में क्रमशः OP, OQ और OR पर स्थित बिन्दु A, B और C इस प्रकार हैं कि $AB \parallel PQ$ और $AC \parallel PR$ है। दर्शाइए कि $BC \parallel QR$ है। 2

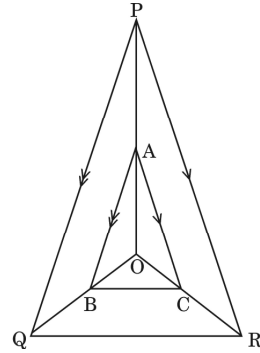

23. बगल में बनी आकृति में, केंद्र O वाले एक वृत्त पर स्थित बिंदु T पर, PT एक स्पर्श रेखा है। यदि $\angle TPO = 30^\circ$ है, तो x का मान ज्ञात कीजिए। 2

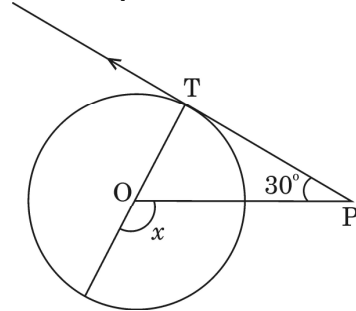



(Assertion - Reason type questions)

In question numbers **19** and **20**, a statement of **Assertion (A)** is followed by a statement of **Reason (R)**. Choose the correct option :

- (a) Both Assertion (A) and Reason (R) are true and Reason (R) gives the correct explanation of Assertion (A).
- (b) Both Assertion (A) and Reason (R) are true but Reason (R) does not give the correct explanation of Assertion (A).
- (c) Assertion (A) is true but Reason (R) is false.
- (d) Assertion (A) is false but Reason (R) is true.

19. Assertion (A) : A tangent to a circle is perpendicular to the radius through the point of contact.

Reason (R) : The lengths of tangents drawn from an external point to a circle are equal. 1

20. Assertion (A) : If one root of the quadratic equation $4x^2 - 10x + (k - 4) = 0$ is reciprocal of the other, then value of k is 8.

Reason (R) : Roots of the quadratic equation $x^2 - x + 1 = 0$ are real. 1

SECTION - B

Section - B comprises of **Very Short Answer (VSA)** questions of **2** marks each.

21. (A) Find the discriminant of the quadratic equation $3x^2 - 2x + \frac{1}{3} = 0$ and hence find the nature of its roots. 2

OR

(B) Find the roots of the quadratic equation $x^2 - x - 2 = 0$. 2

22. In the adjoining figure, A, B and C are points on OP, OQ and OR respectively such that $AB \parallel PQ$ and $AC \parallel PR$. Show that $BC \parallel QR$. 2

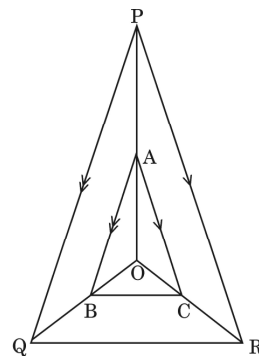

23. In the adjoining figure, PT is a tangent at T to the circle with centre O. If $\angle TPO = 30^\circ$, find the value of x. 2

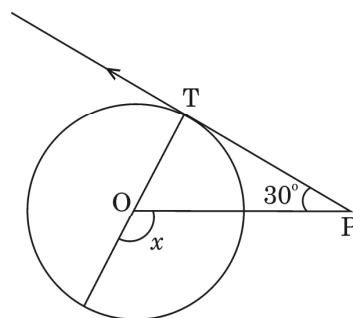



24. (A) उस बिंदु के निर्देशांक ज्ञात कीजिए जो बिंदुओं A (-1, 7) और B (4, -3) को जोड़ने वाले रेखाखंड को आंतरिक रूप से 2 : 3 के अनुपात में विभाजित करता है। 2

अथवा

- (B) यदि बिंदु A (2, 3), B (-5, 6), C (6, 7) और D (p, 4) एक समांतर चतुर्भुज ABCD के शीर्ष हों, तो p का मान ज्ञात कीजिए। 2

25. एक समकोण त्रिभुज PQR, जो Q पर समकोण है, में यदि $\tan P = \sqrt{3}$ है, तो $2 \sin P \cos P$ का मान ज्ञात कीजिए। 2

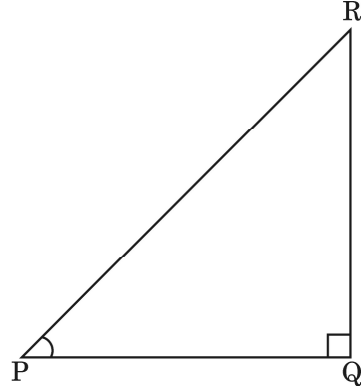

खण्ड - ग

खण्ड - ग में लघु-उत्तर (SA) प्रकार के प्रश्न हैं और प्रत्येक प्रश्न के 3 अंक हैं।

26. सिद्ध कीजिए कि $\frac{1 + \sec \theta}{\sec \theta} = \frac{\sin^2 \theta}{1 - \cos \theta}$ 3

27. एक निष्पक्ष सिक्का दो बार उछाला जाता है। प्रायिकता ज्ञात कीजिए : 3
- (a) कम से कम एक चित प्राप्त करने की ।
- (b) केवल एक पट प्राप्त करने की ।
- (c) अधिक से अधिक एक चित प्राप्त करने की ।

28. द्विघात समीकरण $x^2 + 6x + 8$ के शून्यकों को ज्ञात कीजिए और शून्यकों तथा गुणांकों के बीच के संबंध की सत्यता की जाँच कीजिए। 3

29. त्रिज्या 7 सेमी. वाले एक वृत्त के त्रिज्यखंड का क्षेत्रफल ज्ञात कीजिए, जिसका केंद्रीय कोण 90° है। साथ ही, संगत दीर्घ त्रिज्यखंड का क्षेत्रफल भी ज्ञात कीजिए। 3

30. (A) सिद्ध कीजिए कि बाह्य बिंदु से वृत्त पर खींची गई स्पर्श रेखाओं की लम्बाई बराबर होती है। 3

अथवा

- (B) केंद्र O के दो संकेंद्रीय वृत्तों की त्रिज्याएँ 3 सेमी. और 5 सेमी. हैं। बड़े वृत्त की जीवा AB, जो छोटे वृत्त को बिंदु P पर स्पर्श करती है, की लम्बाई ज्ञात कीजिए। 3

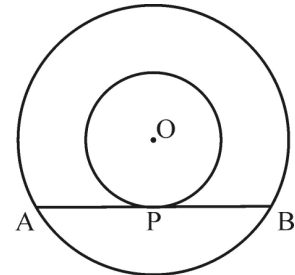



24. (A) Find the coordinates of the point which divides the join of A (-1, 7) and B (4, -3) in the ratio 2 : 3. 2

OR

- (B) If the points A (2, 3), B (-5, 6), C (6, 7) and D (p, 4) are the vertices of a parallelogram ABCD, find the value of p. 2

25. In a right triangle PQR, right angled at Q. If $\tan P = \sqrt{3}$, then evaluate $2 \sin P \cos P$. 2

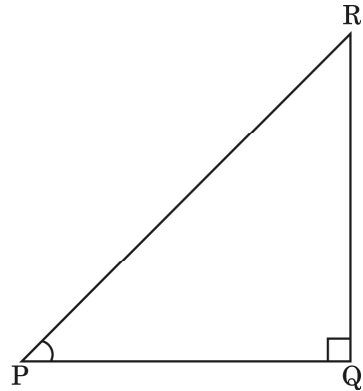

SECTION - C

Section - C comprises of Short Answer (SA) type questions of 3 marks each.

26. Prove that $\frac{1 + \sec \theta}{\sec \theta} = \frac{\sin^2 \theta}{1 - \cos \theta}$ 3

27. An unbiased coin is tossed twice. Find the probability of getting : 3
 (a) at least one head.
 (b) exactly one tail.
 (c) at most one head.

28. Find the zeroes of the quadratic polynomial $x^2 + 6x + 8$ and verify the relationship between the zeroes and the coefficients. 3

29. Find the area of the sector of a circle of radius 7 cm and of central angle 90° . Also, find the area of corresponding major sector. 3

30. (A) Prove that the lengths of tangents drawn from an external point to a circle are equal. 3

OR

- (B) Two concentric circles with centre O are of radii 3 cm and 5 cm. Find the length of chord AB of the larger circle which touches the smaller circle at P. 3

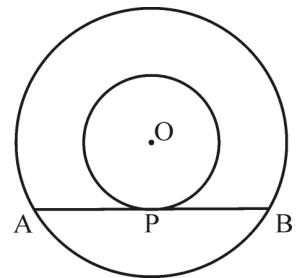



31. (A) किराए पर पुस्तकें देने वाले किसी पुस्तकालय का प्रथम तीन दिनों का एक नियत किराया है और उसके बाद प्रत्येक अतिरिक्त दिन का अलग किराया है। रितिक ने सात दिनों तक एक पुस्तक रखने के लिए ₹ 27 अदा किए, जबकि मनमोहन ने एक पुस्तक पाँच दिनों तक रखने के लिए ₹ 21 अदा किए। नियत किराया तथा प्रत्येक अतिरिक्त दिन का किराया ज्ञात कीजिए।

3

अथवा

- (B) 'a' और 'b' के मान ज्ञात कीजिए, जिनके लिए निम्न रैखिक समीकरणों के युग्म के अपरिमित रूप से अनेक हल होंगे :

3

$$3x + 4y = 12, (a + b)x + 2(a - b)y = 24$$

खण्ड - घ

खण्ड - घ में दीर्घ-उत्तर (LA) प्रकार के प्रश्न हैं और प्रत्येक प्रश्न 5 अंक का है।

32. एक ताप विद्युत संयंत्र में पानी जमा करने और बाद में इससे भाप बनाने के लिए बॉयलर लगे हैं। ऐसे एक बॉयलर के बीच का हिस्सा बेलनाकार और दोनों सिरों का हिस्सा अर्धगोलाकार है। बेलनाकार भाग की लम्बाई 7 मी. और इसकी त्रिज्या $\frac{7}{2}$ मी. है। बॉयलर का कुल पृष्ठीय क्षेत्रफल तथा आयतन ज्ञात कीजिए। बेलनाकार हिस्से के आयतन का, एक अर्धगोलाकार हिस्से के आयतन से अनुपात भी ज्ञात कीजिए।

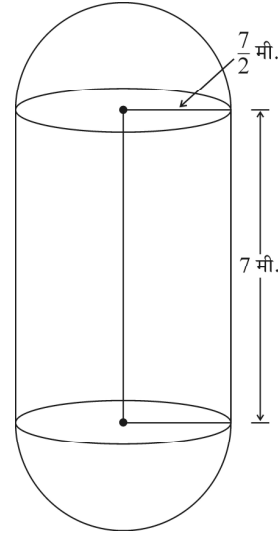

5

33. नीचे दिया गया बंटन 100 परिवारों की मासिक बिजली की खपत को दर्शाता है :

मासिक खपत (यूनिटों में)	130-140	140-150	150-160	160-170	170-180	180-190	190-200
परिवारों की संख्या	5	9	17	28	24	10	7

उपरोक्त आँकड़ों का माध्यक ज्ञात कीजिए।

5

34. (A) एक A.P. का पहला पद - 5 और अन्तिम पद 45 है। यदि A.P. के सभी पदों का योग 120 है, तो पदों की संख्या और सार्व अन्तर ज्ञात कीजिए।

5

अथवा

- (B) यदि एक A.P. के पहले 7 पदों का योग 49 और पहले 17 पदों का योग 289 है, तो पहले n पदों का योग ज्ञात कीजिए।

5





31. (A) A lending library has a fixed charge for first three days and an additional charge for each day thereafter. Rittik paid ₹ 27 for a book kept for 7 days and Manmohan paid ₹ 21 for a book kept for 5 days. Find the fixed charges and the charge for each extra day. 3

OR

- (B) Find the values of 'a' and 'b' for which the system of linear equations $3x + 4y = 12$, $(a + b)x + 2(a - b)y = 24$ has infinite number of solutions. 3

SECTION - D

Section - D comprises of Long Answer (LA) type questions of 5 marks each.

32. The boilers are used in thermal power plants to store water and then used to produce steam. One such boiler consists of a cylindrical part in middle and two hemispherical parts at its both ends. Length of the cylindrical part is 7m and radius of cylindrical part is $\frac{7}{2}$ m.

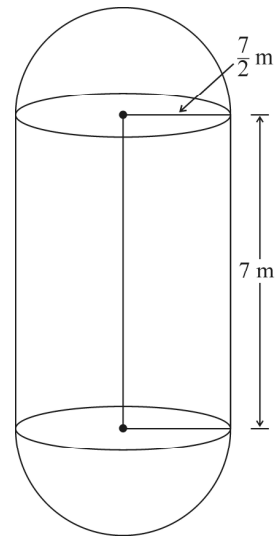

Find the total surface area and the volume of the boiler. Also, find the ratio of the volume of cylindrical part to the volume of one hemispherical part. 5

33. The following table gives the monthly consumption of electricity of 100 families :

Monthly Consumption (in units)	130-140	140-150	150-160	160-170	170-180	180-190	190-200
Number of families	5	9	17	28	24	10	7

Find the median of the above data. 5

34. (A) The first term of an A.P. is -5 and the last term is 45 . If the sum of all the terms of the A.P. is 120 , find the number of terms and the common difference. 5

OR

- (B) If the sum of first 7 terms of an A.P. is 49 and that of first 17 terms is 289 , find the sum of first n terms. 5





35. (A) समुद्र-तल से 75 मी. ऊँचे लाइट हाउस के शिखर से देखने पर दो समुद्री जहाजों के अवनमन कोण 30° और 45° है। यदि लाइट हाउस के एक ही ओर एक जहाज दूसरे जहाज के ठीक पीछे हो, तो जहाजों के बीच की दूरी ज्ञात कीजिए।

(यहाँ आप $\sqrt{3} = 1.73$ ले सकते हैं)

5

अथवा

- (B) भूमि के एक बिंदु P से एक 10 मी. ऊँचे भवन के शिखर का उन्नयन कोण 30° है। भवन के शिखर पर एक ध्वज को लहराया गया है और P से ध्वज के शिखर का उन्नयन कोण 45° है। ध्वजदंड की लम्बाई और बिंदु P से भवन की दूरी ज्ञात कीजिए।

(यहाँ आप $\sqrt{3} = 1.73$ ले सकते हैं)

5

खण्ड - ड

खण्ड - ड में 3 प्रकरण अध्ययन / परिच्छेद आधारित प्रश्न हैं जिनमें प्रत्येक के 4 अंक हैं।

36. खुशी अपने जन्मदिन की पार्टी का आयोजन करना चाहती है। स्वास्थ्य के प्रति जागरूक होने के कारण, वह पार्टी में केवल फल ही परोसने का फैसला करती है। वह 36 सेब और 60 केले खरीदती है और सबको एकसमान मात्रा में फल देने का निर्णय लेती है।



उपरोक्त जानकारी के आधार पर, निम्न प्रश्नों के उत्तर दीजिए :

- (i) अधिकतम कितने अतिथि, खुशी आमंत्रित कर सकती है ? 1
(ii) प्रत्येक अतिथि को कितने सेब और केले प्राप्त होंगे ? 1
(iii) (a) यदि खुशी 42 आम और जोड़ना चाहें, तो अधिकतम कितने अतिथि वह आमंत्रित कर सकती है ? 2

अथवा

- (b) यदि 1 दर्जन केलों का मूल्य 60 रु., 1 सेब का मूल्य 15 रु. और 1 आम का मूल्य 20 रु. है, तो 60 केले, 36 सेब और 42 आम खरीदने के लिए कितनी राशि खर्च करनी होगी ? 2

37. नीचे बने चित्रों तथा आकृतियों को ध्यानपूर्वक देखिए और प्रश्नों के उत्तर दीजिए :

चित्र क

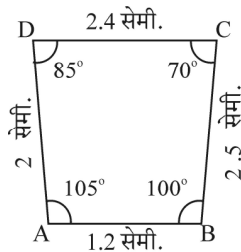

क (i)

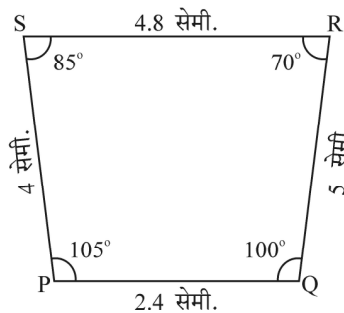

क (ii)





35. (A) As observed from the top of a 75 m high light house from the sea-level, the angles of depression of two ships are 30° and 45° . If one ship is exactly behind the other on the same side of the light house, find the distance between the two ships. (use $\sqrt{3} = 1.73$) 5

OR

- (B) From a point P on the ground, the angle of elevation of the top of a 10 m tall building is 30° . A flag is hoisted at the top of the building and the angle of elevation of the top of the flagstaff from P is 45° . Find the length of the flagstaff and the distance of the building from the point P. (use $\sqrt{3} = 1.73$) 5

SECTION - E

Section - E comprises of 3 Case Study / Passage Based questions of 4 marks each.

36. Khushi wants to organize her birthday party. Being health conscious, she decided to serve only fruits in her birthday party. She bought 36 apples and 60 bananas and decided to distribute fruits equally among all.

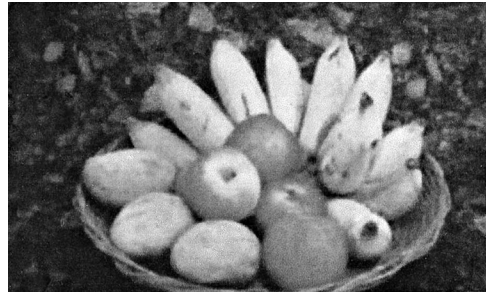

Based on the above information, answer the following questions :

- (i) How many guests Khushi can invite at the most ? 1
 (ii) How many apples and bananas will each guest get ? 1
 (iii) (a) If Khushi decides to add 42 mangoes, how many guests Khushi can invite at the most ? 2

OR

- (b) If the cost of 1 dozen of bananas is ₹ 60, the cost of 1 apple is ₹ 15 and cost of 1 mango is ₹ 20, find the total amount spent on 60 bananas, 36 apples and 42 mangoes. 2

37. Observe the figures given below carefully and answer the questions :

Figure A

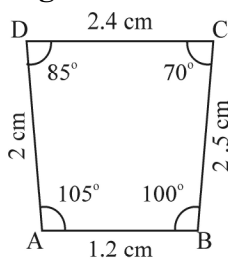

A (i)

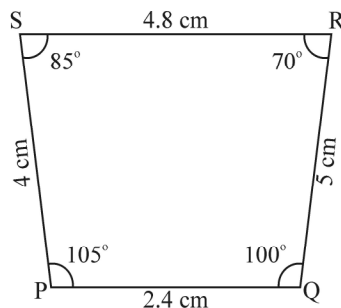

A (ii)





चित्र ख

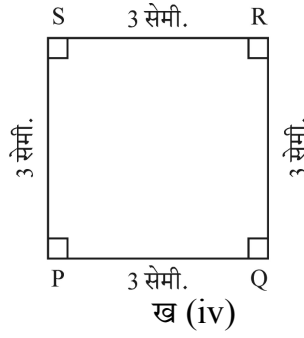
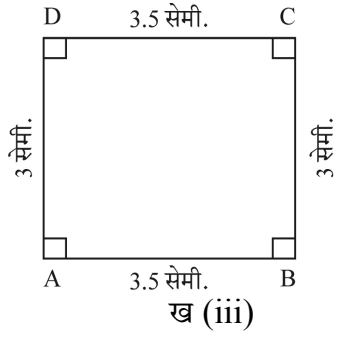

चित्र ग

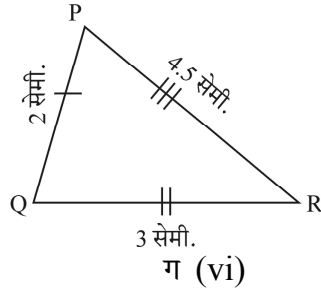
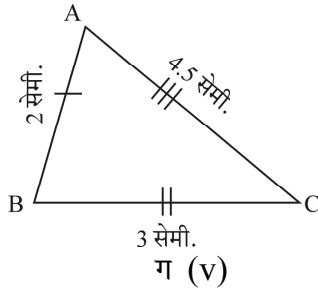

- (i) वह चित्र बताइए जिसमें दोनों आकृतियाँ परस्पर समरूप हैं। 1
(ii) वह चित्र बताइए जिसमें दोनों आकृतियाँ सर्वांगसम हैं। 1
(iii) (a) सिद्ध कीजिए कि सर्वांगसम त्रिभुज समरूप भी होते हैं परन्तु विपरीत नहीं। 2

अथवा

- (b) दो समरूप त्रिभुजों को सर्वांगसम होने के लिए कम से कम क्या और दिया होना चाहिए ? 2

38. लगातार कई घंटों तक मोबाइल स्क्रीन का इस्तेमाल करने से आँखों की रोशनी कमजोर और सिर दर्द होने लगता है। बच्चे जिनको “PUBG” खेलने की लत लग जाती है, जल्दी ही तनावग्रस्त हो जाते हैं। PUBG खेलने के दुष्परिणामों के बारे में सामाजिक जागरूकता बढ़ाने के लिए, एक विद्यालय ‘BAN PUBG’ अभियान शुरू करने का फैसला करता है, जिसमें बच्चों को आयताकार अभियान तख्ती बनाने को कहता है। कक्षा X के एक विद्यार्थी द्वारा बनाई गई अभियान तख्ती चित्र में दिखाई गई है।

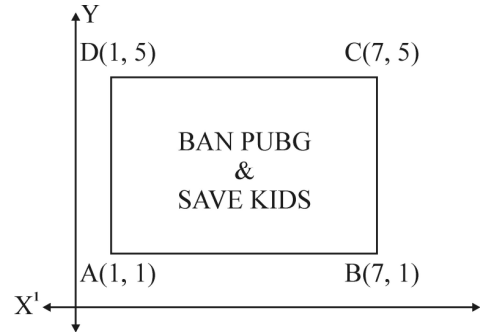

उपरोक्त जानकारी के आधार पर, निम्न प्रश्नों के उत्तर दीजिए :

- (i) विकर्ण AC तथा BD के प्रतिच्छेदन बिन्दु के निर्देशांक ज्ञात कीजिए। 1
(ii) विकर्ण AC की लम्बाई ज्ञात कीजिए। 1
(iii) (a) अभियान तख्ती ABCD का क्षेत्रफल ज्ञात कीजिए। 2

अथवा

- (b) भुजा AB की लम्बाई का अनुपात, विकर्ण AC की लम्बाई से, ज्ञात कीजिए। 2





Figure B

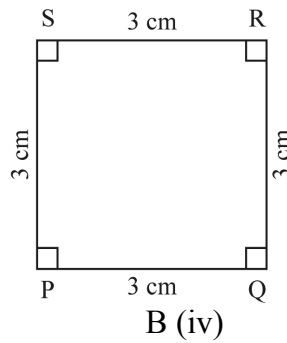
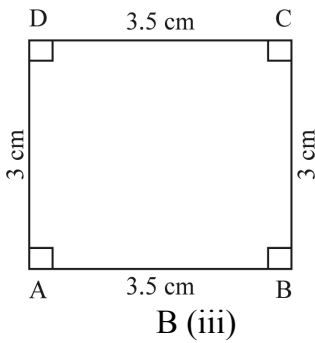
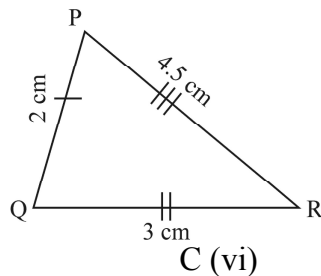
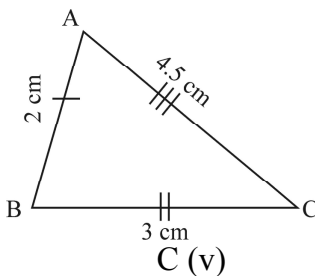

Figure C



- (i) Name the figure(s) wherein two figures are similar. 1
- (ii) Name the figure(s) wherein the figures are congruent. 1
- (iii) (a) Prove that congruent triangles are also similar but not the converse. 2

OR

- (b) What more is least needed for two similar triangles to be congruent? 2

38. Use of mobile screen for long hours makes your eye sight weak and give you headaches. Children who are addicted to play “PUBG” can get easily stressed out. To raise social awareness about ill effects of playing PUBG, a school decided to start ‘BAN PUBG’ campaign, in which students are asked to prepare campaign board in the shape of a rectangle. One such campaign board made by class X student of the school is shown in the figure.

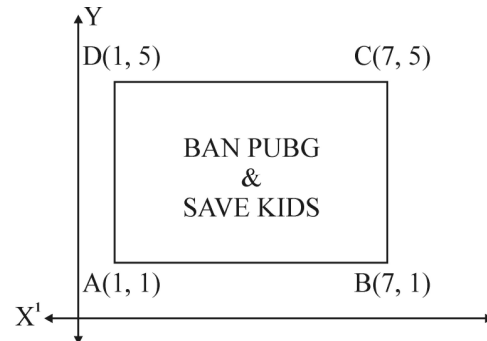

Based on the above information, answer the following questions :

- (i) Find the coordinates of the point of intersection of diagonals AC and BD. 1
- (ii) Find the length of the diagonal AC. 1
- (iii) (a) Find the area of the campaign Board ABCD. 2

OR

- (b) Find the ratio of the length of side AB to the length of the diagonal AC. 2





430/4/3

16



Marking Scheme
Strictly Confidential
(For Internal and Restricted use only)
Secondary School Examination, 2023
SUBJECT NAME MATHEMATICS (BASIC) (SUBJECT CODE 241) (PAPER CODE 430/4/3)

General Instructions: -

1	You are aware that evaluation is the most important process in the actual and correct assessment of the candidates. A small mistake in evaluation may lead to serious problems which may affect the future of the candidates, education system and teaching profession. To avoid mistakes, it is requested that before starting evaluation, you must read and understand the spot evaluation guidelines carefully.
2	“Evaluation policy is a confidential policy as it is related to the confidentiality of the examinations conducted, Evaluation done and several other aspects. Its’ leakage to public in any manner could lead to derailment of the examination system and affect the life and future of millions of candidates. Sharing this policy/document to anyone, publishing in any magazine and printing in News Paper/Website etc may invite action under various rules of the Board and IPC.”
3	Evaluation is to be done as per instructions provided in the Marking Scheme. It should not be done according to one’s own interpretation or any other consideration. Marking Scheme should be strictly adhered to and religiously followed. However, while evaluating, answers which are based on latest information or knowledge and/or are innovative, they may be assessed for their correctness otherwise and due marks be awarded to them. In class-X, while evaluating two competency-based questions, please try to understand given answer and even if reply is not from marking scheme but correct competency is enumerated by the candidate, due marks should be awarded.
4	The Marking scheme carries only suggested value points for the answers. These are in the nature of Guidelines only and do not constitute the complete answer. The students can have their own expression and if the expression is correct, the due marks should be awarded accordingly.
5	The Head-Examiner must go through the first five answer books evaluated by each evaluator on the first day, to ensure that evaluation has been carried out as per the instructions given in the Marking Scheme. If there is any variation, the same should be zero after deliberation and discussion. The remaining answer books meant for evaluation shall be given only after ensuring that there is no significant variation in the marking of individual evaluators.
6	Evaluators will mark($\sqrt{\quad}$) wherever answer is correct. For wrong answer CROSS ‘X’ be marked. Evaluators will not put right (\checkmark) while evaluating which gives an impression that answer is correct and no marks are awarded. This is the most common mistake which evaluators are committing.
7	If a question has parts, please award marks on the right-hand side for each part. Marks awarded for different parts of the question should then be totaled up and written in the left-hand margin and encircled. This may be followed strictly.
8	If a question does not have any parts, marks must be awarded in the left-hand margin and encircled. This may also be followed strictly.
9	If a student has attempted an extra question, answer of the question deserving more marks should be retained and the other answer scored out with a note “Extra Question” . However, for MCQs (Q1 to Q20), only first attempt to be evaluated.



10	No marks to be deducted for the cumulative effect of an error. It should be penalized only once.
11	A full scale of marks _____(example 0 to 80/70/60/50/40/30 marks as given in Question Paper) has to be used. Please do not hesitate to award full marks if the answer deserves it.
12	Every examiner has to necessarily do evaluation work for full working hours i.e., 8 hours every day and evaluate 20 answer books per day in main subjects and 25 answer books per day in other subjects (Details are given in Spot Guidelines).
13	Ensure that you do not make the following common types of errors committed by the Examiner in the past:- <ul style="list-style-type: none"> ● Leaving answer or part thereof unassessed in an answer book. ● Giving more marks for an answer than assigned to it. ● Wrong totaling of marks awarded on an answer. ● Wrong transfer of marks from the inside pages of the answer book to the title page. ● Wrong question wise totaling on the title page. ● Wrong totaling of marks of the two columns on the title page. ● Wrong grand total. ● Marks in words and figures not tallying/not same. ● Wrong transfer of marks from the answer book to online award list. ● Answers marked as correct, but marks not awarded. (Ensure that the right tick mark is correctly and clearly indicated. It should merely be a line. Same is with the X for incorrect answer.) ● Half or a part of answer marked correct and the rest as wrong, but no marks awarded.
14	While evaluating the answer books if the answer is found to be totally incorrect, it should be marked as cross (X) and awarded zero (0)Marks.
15	Any un assessed portion, non-carrying over of marks to the title page, or totaling error detected by the candidate shall damage the prestige of all the personnel engaged in the evaluation work as also of the Board. Hence, in order to uphold the prestige of all concerned, it is again reiterated that the instructions be followed meticulously and judiciously.
16	The Examiners should acquaint themselves with the guidelines given in the “ Guidelines for spot Evaluation ” before starting the actual evaluation.
17	Every Examiner shall also ensure that all the answers are evaluated, marks carried over to the title page, correctly totaled and written in figures and words.
18	The candidates are entitled to obtain photocopy of the Answer Book on request on payment of the prescribed processing fee. All Examiners/Additional Head Examiners/Head Examiners are once again reminded that they must ensure that evaluation is carried out strictly as per value points for each answer as given in the Marking Scheme.



MARKING SCHEME MATHEMATICS (BASIC)

SECTION A

1. The value of k for which the equations $3x - y + 8 = 0$ and $6x - ky + 16 = 0$ represent coincident lines is :

- (a) $\frac{1}{2}$ (b) $-\frac{1}{2}$ (c) 2 (d) -2

Ans. (c) 2

1

2. A circle of radius 5.2 cm has two tangents AB and CD parallel to each other. What is the distance between the two tangents ?

- (a) 5.2 cm (b) 10.4 cm (c) 20.8 cm (d) can't find

Ans. (b) 10.4 cm

1

3. The number of polynomials having zeroes -3 and 4 is :

- (a) 1 (b) 2 (c) 3 (d) more than 3

Ans. (d) more than 3

1

4. If the perimeter and the area of a circle are numerically equal, then the radius of the circle is :

- (a) 2 units (b) π units (c) 4 units (d) 2π units

Ans. (a) 2 units

1

5. A quadratic equation whose one root is 2 and the sum of whose roots is zero, is :

- (a) $x^2 + 4 = 0$ (b) $x^2 - 2 = 0$ (c) $4x^2 - 1 = 0$ (d) $x^2 - 4 = 0$

Ans. (d) $x^2 - 4 = 0$

1

6. Which of the following is **not** a quadratic equation ?

- (a) $2(x-1)^2 = 4x^2 - 2x + 1$ (b) $2x - x^2 = x^2 + 5$
 (c) $(\sqrt{2}x + \sqrt{3})^2 + x^2 = 3x^2 - 5x$ (d) $(x^2 + 2x)^2 = x^4 + 3 + 4x^3$

Ans. (c) $(\sqrt{2}x + \sqrt{3})^2 + x^2 = 3x^2 - 5x$

1



7. How many tangents can be drawn to a circle from a point on it ?
(a) One (b) Two (c) Infinite (d) Zero

Ans. (a) One

1

8. Which of the following **cannot** be the probability of an event ?
(a) 0.1 (b) $\frac{5}{3}$ (c) 3% (d) $\frac{1}{3}$

Ans. (b) $\frac{5}{3}$

1

9. The angle of elevation of the top of a 30 m high tower at a point 30 m away from the base of the tower is :
(a) 30° (b) 45° (c) 60° (d) 90°

Ans. (b) 45°

1

10. The mode of the numbers 2, 3, 3, 4, 5, 4, 4, 5, 3, 4, 2, 6, 7 is :
(a) 2 (b) 3 (c) 4 (d) 5

Ans. (c) 4

1

11. If the pair of linear equations $x - y = 1$, $x + ky = 5$ has a unique solution $x = 2$, $y = 1$, then the value of k is :
(a) -2 (b) -3 (c) 3 (d) 4

Ans. (c) 3

1

12. (HCF \times LCM) for the numbers 70 and 40 is :
(a) 10 (b) 280 (c) 2800 (d) 70

Ans. (c) 2800

1

13. The number $(5 - 3\sqrt{5} + \sqrt{5})$ is :
(a) an integer (b) a rational number
(c) an irrational number (d) a whole number

Ans. (c) an irrational number

1

14. If $p(x) = x^2 + 5x + 6$, then $p(-2)$ is :
(a) 20 (b) 0 (c) -8 (d) 8

Ans. (b) 0

1



15. If $\triangle ABC \sim \triangle DEF$ and $\angle A = 47^\circ$, $\angle E = 83^\circ$, then $\angle C$ is equal :
(a) 47° (b) 50° (c) 83° (d) 130°

Ans. (b) 50°

1

-
16. From a well-shuffled deck of 52 playing cards, a card is drawn at random. What is the probability of getting a red queen ?

- (a) $\frac{1}{52}$ (b) $\frac{1}{26}$ (c) $\frac{1}{13}$ (d) $\frac{12}{13}$

Ans. (b) $\frac{1}{26}$

1

-
17. What is the length of arc of a circle of radius 7 cm which subtends an angle of 90° at the centre of the circle ?

- (a) 22 cm (b) 11 cm (c) $\frac{77}{2}$ cm (d) $\frac{11}{2}$ cm

Ans. (b) 11 cm

1

-
18. $(3 \sin^2 30^\circ - 4 \cos^2 60^\circ)$ is equal to :

- (a) $\frac{5}{4}$ (b) $-\frac{3}{4}$ (c) $-\frac{1}{4}$ (d) $-\frac{9}{4}$

Ans. (c) $-\frac{1}{4}$

1

In question numbers 19 and 20, a statement of **Assertion (A)** is followed by a statement of **Reason (R)**. Choose the correct option :

- (a) Both Assertion (A) and Reason (R) are true and Reason (R) gives the correct explanation of Assertion (A).
(b) Both Assertion (A) and Reason (R) are true but Reason (R) does not give the correct explanation of Assertion (A).
(c) Assertion (A) is true but Reason (R) is false.
(d) Assertion (A) is false but Reason (R) is true.

19. **Assertion (A)** : A tangent to a circle is perpendicular to the radius through the point of contact.

Reason (R) : The lengths of tangents drawn from an external point to a circle are equal.

Ans. (b) Both Assertion (A) and Reason (R) are true but Reason (R) does not give the correct explanation of Assertion (A)

1



20. **Assertion (A)** : If one root of the quadratic equation $4x^2 - 10x + (k - 4) = 0$ is reciprocal of the other, then value of k is 8.

Reason (R) : Roots of the quadratic equation $x^2 - x + 1 = 0$ are real.

Ans. (c) Assertion (A) is true but Reason (R) is false

1

SECTION B

21. (A) Find the discriminant of the quadratic equation $3x^2 - 2x + \frac{1}{3} = 0$ and hence find the nature of its roots.

Solution: $3x^2 - 2x + \frac{1}{3} = 0$

$a = 3, b = -2, c = \frac{1}{3}$

Discriminant (D) = $b^2 - 4ac = (-2)^2 - 4(3)\left(\frac{1}{3}\right) = 0$

\therefore Roots are real and equal

$\frac{1}{2}$

1

$\frac{1}{2}$

OR

(B) Find the roots of the quadratic equation $x^2 - x - 2 = 0$.

Solution: $x^2 - x - 2 = 0$

$(x - 2)(x + 1) = 0$

$x = 2, x = -1$

1

$\frac{1}{2} + \frac{1}{2}$

22. In the adjoining figure, A, B and C are points on OP, OQ and OR respectively such that $AB \parallel PQ$ and $AC \parallel PR$. Show that $BC \parallel QR$.

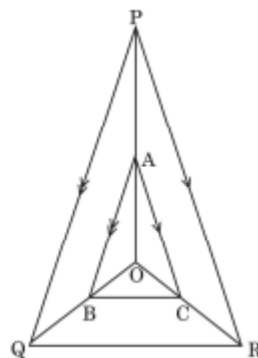

Solution: In ΔPOQ , $AB \parallel PQ$

$\Rightarrow \frac{OA}{AP} = \frac{OB}{BQ}$

(By Thales Theorem) _____ (i)

$\frac{1}{2}$

In ΔPOR , $AC \parallel PR$

$\Rightarrow \frac{OA}{AP} = \frac{OC}{CR}$

(By Thales Theorem) _____ (ii)

$\frac{1}{2}$

From (i) and (ii) $\frac{OB}{BQ} = \frac{OC}{CR}$

$\frac{1}{2}$
 $\frac{1}{2}$

\therefore In ΔQOR , $BC \parallel QR$ (By converse of Thales theorem)

23. In the adjoining figure, PT is a tangent at T to the circle with centre O . If $\angle TPO = 30^\circ$, find the value of x .

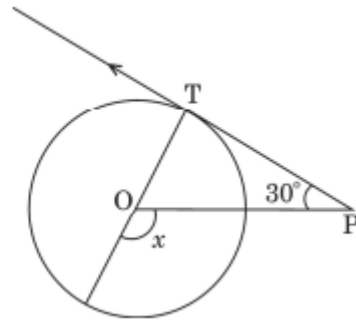

Solution:

$\angle OTP = 90^\circ$ (tangent \perp radius at the point of contact)

Getting $x = 120^\circ$

1
1

24. (A) Find the coordinates of the point which divides the join of $A(-1, 7)$ and $B(4, -3)$ in the ratio $2 : 3$.

Solution:

$$x = \frac{2(4) + 3(-1)}{2 + 3} = \frac{8 - 3}{5} = 1$$

$$y = \frac{2(-3) + 3(7)}{2 + 3} = \frac{15}{5} = 3$$

Coordinates of the required point are $(1, 3)$

OR

- (B) If the points $A(2, 3)$, $B(-5, 6)$, $C(6, 7)$ and $D(p, 4)$ are the vertices of a parallelogram $ABCD$, find the value of p .

Solution: Mid point of $AC =$ Mid point of BD

$$\therefore \left(\frac{2+6}{2}, \frac{3+7}{2} \right) = \left(\frac{-5+p}{2}, \frac{6+4}{2} \right)$$

$$\frac{-5+p}{2} = 4 \Rightarrow p = 13$$

1
1

25. In a right triangle PQR, right angled at Q. If $\tan P = \sqrt{3}$, then evaluate $2 \sin P \cos P$.

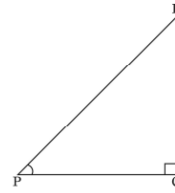

Solution: $\sin P = \frac{\sqrt{3}}{2}$, $\cos P = \frac{1}{2}$

$$\frac{1}{2} + \frac{1}{2}$$

$$2 \sin P \cos P = 2 \left(\frac{\sqrt{3}}{2} \right) \left(\frac{1}{2} \right) = \frac{\sqrt{3}}{2}$$

1

SECTION C

26. Prove that $\frac{1 + \sec \theta}{\sec \theta} = \frac{\sin^2 \theta}{1 - \cos \theta}$

Solution: LHS = $\frac{1 + \sec \theta}{\sec \theta} = \frac{1 + \frac{1}{\cos \theta}}{\frac{1}{\cos \theta}} = 1 + \cos \theta$

1

$$= \frac{(1 - \cos \theta)(1 + \cos \theta)}{(1 - \cos \theta)}$$

1

$$= \frac{1 - \cos^2 \theta}{1 - \cos \theta} = \frac{\sin^2 \theta}{1 - \cos \theta} = \text{RHS}$$

1

27. An unbiased coin is tossed twice. Find the probability of getting :

- at least one head.
- exactly one tail.
- at most one head.

Solution: $S = \{HH, HT, TH, TT\}$

(a) $P(\text{at least one head}) = \frac{3}{4}$

1

(b) $P(\text{exactly one tail}) = \frac{2}{4}$ or $\frac{1}{2}$

1

(c) $P(\text{at most one head}) = \frac{3}{4}$

1

28. Find the zeroes of the quadratic polynomial $x^2 + 6x + 8$ and verify the relationship between the zeroes and the coefficients.

Solution: $x^2 + 6x + 8 = (x + 4)(x + 2)$

1

\Rightarrow Zeroes are $-4, -2$

1

Sum of zeroes = $-4 + (-2) = -6 = \frac{-6}{1} = \frac{-\text{Coeff. of } x}{\text{Coeff. of } x^2}$

1

2



$$\text{Product of zeroes} = (-4)(-2) = 8 = \frac{8}{1} = \frac{\text{Constant term}}{\text{Coeff. of } x^2} \quad \frac{1}{2}$$

29. Find the area of the sector of a circle of radius 7 cm and of central angle 90° . Also, find the area of corresponding major sector.

Solution: $r = 7$ cm, $\theta = 90^\circ$

$$\begin{aligned} \text{Area of sector} &= \frac{\pi r^2 \theta}{360} = \frac{22}{7} \times 7 \times 7 \times \frac{90}{360} && 1 \\ &= \frac{77}{2} \text{ cm}^2 \text{ or } 38.5 \text{ cm}^2 && \frac{1}{2} \end{aligned}$$

$$\text{Area of circle} = \pi r^2 = \frac{22}{7} \times 7 \times 7 = 154 \text{ cm}^2 \quad 1$$

$$\text{Area of major sector} = 154 - 38.5 = 115.5 \text{ cm}^2 \quad \frac{1}{2}$$

30. (A) Prove that the lengths of tangents drawn from an external point to a circle are equal.

Solution:

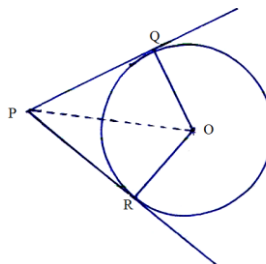

1
(For Fig.)

Given: A circle with centre O and PQ, PR are tangents to the circle from an external point P.

To Prove: $PQ = PR$

Construction: Join OP, OQ, OR

Proof: In $\triangle OPQ$ and $\triangle OPR$

$OP = OP$ (common)

$OQ = OR$ (radii of the same circle)

$\angle OQP = \angle ORP$ (each 90°)

$\Rightarrow \triangle POQ \cong \triangle POR$ (RHS congruence)

$\therefore PQ = PR$

OR

1
2

1
2

- (B) Two concentric circles with centre O are of radii 3 cm and 5 cm. Find the length of chord AB of the larger circle which touches the smaller circle at P.

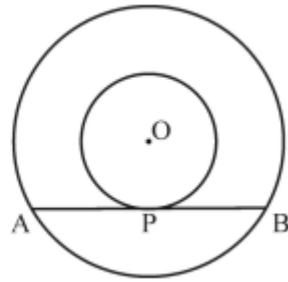

Solution: Join OA and OP

$OP \perp AB$ (radius \perp tangent at the point of contact)

$\frac{1}{2}$

OP is the radius of smaller circle and AB is tangent at P.

AB is chord of larger circle and $OP \perp AB$

$\therefore AP = PB$ (\perp from centre bisects the chord)

1

In right ΔAOP , $AP^2 = OA^2 - OP^2$

$$= (5)^2 - (3)^2 = 16$$

$\frac{1}{2}$

$$AP = 4 \text{ cm} = PB$$

$\frac{1}{2}$

$$\therefore AB = 8 \text{ cm}$$

$\frac{1}{2}$

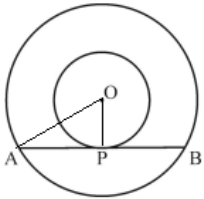

31. (A) A lending library has a fixed charge for first three days and an additional charge for each day thereafter. Rittik paid ₹ 27 for a book kept for 7 days and Manmohan paid ₹ 21 for a book kept for 5 days. Find the fixed charges and the charge for each extra day.

Solution: Let fixed charge be ₹ x

Let charge for each extra day be ₹ y

$$\text{ATQ, } x + 4y = 27$$

1

$$x + 2y = 21$$

1

On solving ; $x = 15$, $y = 3$

$\frac{1}{2} + \frac{1}{2}$

\therefore Fixed charge = ₹ 15

and charge for each extra day = ₹ 3

OR

- (B) Find the values of 'a' and 'b' for which the system of linear equations $3x + 4y = 12$, $(a + b)x + 2(a - b)y = 24$ has infinite number of solutions.

Solution: For Infinite number of solutions $\Rightarrow \frac{a_1}{a_2} = \frac{b_1}{b_2} = \frac{c_1}{c_2}$



$$\frac{3}{a+b} = \frac{4}{2(a-b)} = \frac{12}{24}$$

$$\frac{3}{a+b} = \frac{1}{2} \Rightarrow a+b=6$$

$$\frac{2}{a-b} = \frac{1}{2} \Rightarrow a-b=4$$

On solving, $a = 5$, $b = 1$

1

$\frac{1}{2}$

$\frac{1}{2}$

$\frac{1}{2} + \frac{1}{2}$

SECTION D

32. The boilers are used in thermal power plants to store water and then used to produce steam. One such boiler consists of a cylindrical part in middle and two hemispherical parts at its both ends.

Length of the cylindrical part is 7m and radius of cylindrical part is $\frac{7}{2}$ m.

Find the total surface area and the volume of the boiler. Also, find the ratio of the volume of cylindrical part to the volume of one hemispherical part.

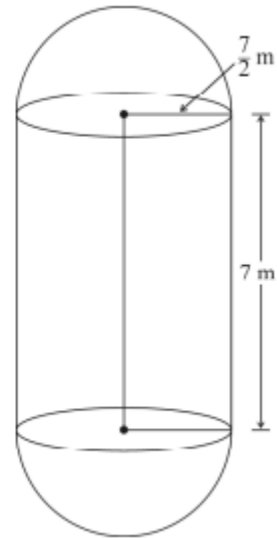

Solution:

$$h = 7 \text{ m}, r = \frac{7}{2} \text{ m}$$

$$\text{Total surface area} = 2\pi rh + 2(2\pi r^2) = 2\pi r(h + 2r)$$

$$= 2 \times \frac{22}{7} \times \frac{7}{2} \left(7 + 2 \times \frac{7}{2} \right)$$

$$= 308 \text{ m}^2$$

$1\frac{1}{2}$

$\frac{1}{2}$

$$\text{Volume of the boiler} = \pi r^2 h + 2 \left(\frac{2}{3} \pi r^3 \right)$$

$$= \frac{22}{7} \times \frac{7}{2} \times \frac{7}{2} \times 7 + \frac{4}{3} \times \frac{22}{7} \times \frac{7}{2} \times \frac{7}{2} \times \frac{7}{2}$$

$$= \frac{2695}{6} \text{ m}^3 \quad \text{or} \quad 449.16 \text{ m}^3$$

$1\frac{1}{2}$

$\frac{1}{2}$



$$\frac{\text{Volume of cylindrical part}}{\text{Volume of one hemispherical part}} = \frac{\pi r^2 h}{\frac{2}{3} \pi r^3} = \frac{3h}{2r} = \frac{3(7)}{2 \times \frac{7}{2}} = \frac{3}{1} \text{ or } 3 : 1$$

33. The following table gives the monthly consumption of electricity of 100 families :

Monthly Consumption (in units)	130-140	140-150	150-160	160-170	170-180	180-190	190-200
Number of families	5	9	17	28	24	10	7

Find the median of the above data.

Solution:

Monthly Consumption	Number of families	cf
130 – 140	5	5
140 – 150	9	14
150 – 160	17	31
160 – 170	28	59
170 – 180	24	83
180 – 190	10	93
190 – 200	7	100
	100	

1
(For Table.)

$$\frac{N}{2} = \frac{100}{2} = 50$$

∴ Median class is 160 – 170

$l = 160$, $h = 10$, $cf = 31$, $f = 28$

$$\text{Median} = l + \frac{\frac{N}{2} - cf}{f} \times h$$

$$= 160 + \frac{50 - 31}{28} \times 10 = 160 + \frac{19}{28} \times 10$$

$$= 166.8$$

1
1
1
2
1
2



34. (A) The first term of an A.P. is -5 and the last term is 45 . If the sum of all the terms of the A.P. is 120 , find the number of terms and the common difference.

Solution:

$$a = -5, a_n = 45$$

$$\Rightarrow a + (n - 1)d = 45$$

$$\Rightarrow (n - 1)d = 50 \quad 1$$

$$S_n = 120 \Rightarrow \frac{n}{2} [2a + (n - 1)d] = 120$$

$$\frac{n}{2} [2(-5) + 50] = 120 \quad 2$$

$$\Rightarrow \frac{n}{2} \times 40 = 120 \Rightarrow n = 6 \quad 1$$

$$\therefore (n - 1)d = 50 \Rightarrow d = 10 \quad 1$$

OR

(B) If the sum of first 7 terms of an A.P. is 49 and that of first 17 terms is 289 , find the sum of first n terms.

Solution:

$$S_7 = 49 \Rightarrow \frac{7}{2} [2a + 6d] = 49 \Rightarrow a + 3d = 7 \quad 1 \frac{1}{2}$$

$$S_{17} = 289 \Rightarrow \frac{17}{2} [2a + 16d] = 289 \Rightarrow a + 8d = 17 \quad 1 \frac{1}{2}$$

On solving, $d = 2, a = 1 \quad \frac{1}{2} + \frac{1}{2}$

$$S_n = \frac{n}{2} [2(1) + (n - 1)2] = n^2 \quad 1$$

35. (A) As observed from the top of a 75 m high light house from the sea-level, the angles of depression of two ships are 30° and 45° . If one ship is exactly behind the other on the same side of the light house, find the distance between the two ships. (use $\sqrt{3} = 1.73$)

Solution:

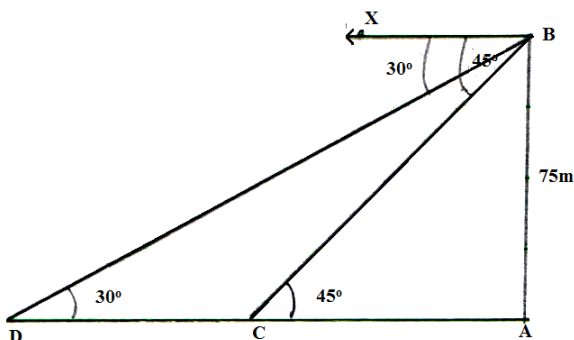

1
(For Fig)

Let $AC = x$, $CD = y$

$$\text{In } \triangle ABC, \tan 45^\circ = \frac{75}{x}$$

$$\Rightarrow x = 75$$

$$\text{In } \triangle ABD, \tan 30^\circ = \frac{75}{x+y} \Rightarrow \frac{1}{\sqrt{3}} = \frac{75}{x+y}$$

$$\Rightarrow x + y = 75\sqrt{3}$$

$$\Rightarrow y = 75(\sqrt{3} - 1)$$

$$\Rightarrow y = 54.75 \text{ m}$$

\therefore Distance between two ships = 54.75 m

OR

(B) From a point P on the ground, the angle of elevation of the top of a 10 m tall building is 30° . A flag is hoisted at the top of the building and the angle of elevation of the top of the flagstaff from P is 45° . Find the length of the flagstaff and the distance of the building from the point P.

(use $\sqrt{3} = 1.73$)

Solution:

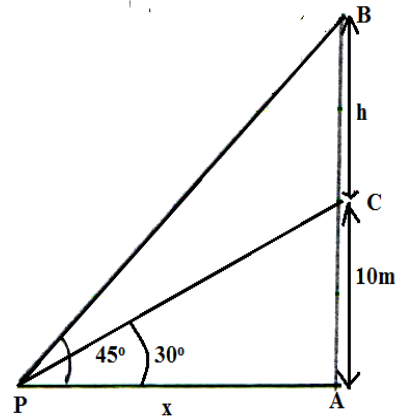

1
(For Fig)

$$\text{In } \triangle APC, \tan 30^\circ = \frac{10}{x}$$

$$\Rightarrow x = 10\sqrt{3}$$

$$\text{In } \triangle APB, \tan 45^\circ = \frac{10+h}{x}$$

$$\Rightarrow x = 10 + h$$

$$\therefore 10\sqrt{3} = 10 + h$$

$$\Rightarrow h = 10(\sqrt{3} - 1)$$

$$= 10 \times 0.73 = 7.3 \text{ m}$$

$\frac{1}{2}$

\therefore Length of flagstaff = 7.3 m

$$\text{Distance of building from P} = x = 10\sqrt{3} \text{ m}$$

$$= 17.3 \text{ m}$$

$\frac{1}{2}$

$\left(\text{only } \frac{1}{2} \text{ mark to be deducted for not using } \sqrt{3} = 1.73 \right)$

SECTION E

36. Khushi wants to organize her birthday party. Being health conscious, she decided to serve only fruits in her birthday party. She bought 36 apples and 60 bananas and decided to distribute fruits equally among all.



Based on the above information, answer the following questions :

- (i) How many guests Khushi can invite at the most ?
- (ii) How many apples and bananas will each guest get ?
- (iii) (a) If Khushi decides to add 42 mangoes, how many guests Khushi can invite at the most ?

OR

- (b) If the cost of 1 dozen of bananas is ₹ 60, the cost of 1 apple is ₹ 15 and cost of 1 mango is ₹ 20, find the total amount spent on 60 bananas, 36 apples and 42 mangoes.

Solution:

- (i) $\text{HCF}(36, 60) = 12$ 1
Khushi can invite at the most 12 guests.
 - (ii) $36 \div 12 = 3, 60 \div 12 = 5$ 1
Each guest will get 3 apples and 5 bananas
 - (iii) (a) $\text{HCF}(36, 60, 42) = 6$ 2
Khushi can invite at the most 6 guests.
- OR**
- (iii) (b) Total cost = $5 \times 60 + 36 \times 15 + 42 \times 20$ 1
 $= ₹1680$ 1

37. Observe the figures given below carefully and answer the questions :

Figure A

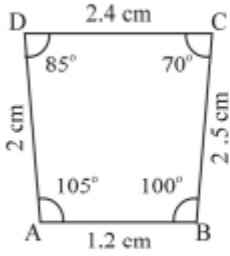

A (i)

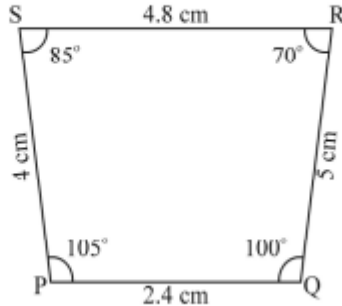

A (ii)

Figure B

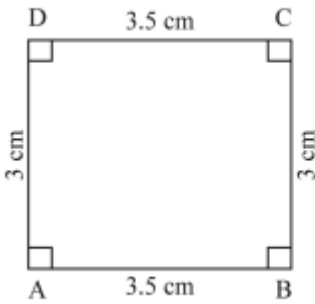

B (iii)

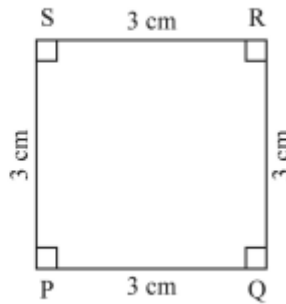

B (iv)

Figure C

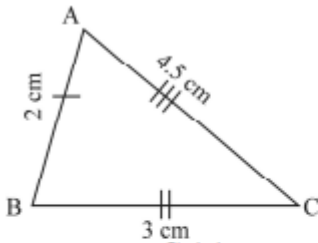

C (v)

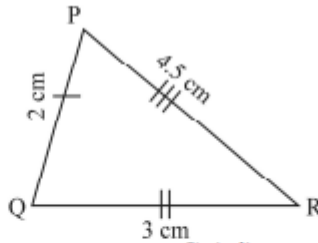

C (vi)

- (i) Name the figure(s) wherein two figures are similar.
- (ii) Name the figure(s) wherein the figures are congruent.
- (iii) (a) Prove that congruent triangles are also similar but not the converse.

OR

- (b) What more is least needed for two similar triangles to be congruent ?

Solution:

(i) Figure A and Figure C

(ii) Figure C

(iii) (a) Triangles are congruent \Rightarrow Corresponding angles are equal

$$\frac{1}{2} + \frac{1}{2}$$

1

1

\Rightarrow Triangles are similar.

$\frac{1}{2}$

Conversely, if triangles are similar then ratio of corresponding sides is same which does not imply corresponding sides are equal

\therefore Triangles may not be congruent.

$\frac{1}{2}$

Note: Any suitable counter example can be given

OR

(iii) (b) One pair of corresponding side must be equal

2

38. Use of mobile screen for long hours makes your eye sight weak and give you headaches. Children who are addicted to play "PUBG" can get easily stressed out. To raise social awareness about ill effects of playing PUBG, a school decided to start 'BAN PUBG' campaign, in which students are asked to prepare campaign board in the shape of a rectangle. One such campaign board made by class X student of the school is shown in the figure.

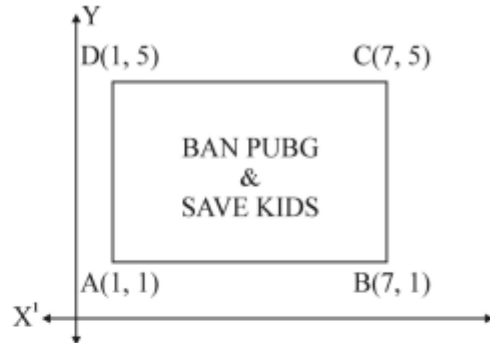

Based on the above information, answer the following questions :

- (i) Find the coordinates of the point of intersection of diagonals AC and BD.
- (ii) Find the length of the diagonal AC.
- (iii) (a) Find the area of the campaign Board ABCD.

OR

- (b) Find the ratio of the length of side AB to the length of the diagonal AC.

Solution:

We know that diagonals of a rectangle bisect each other.

(i) Required point = Mid-point of AC = $\left(\frac{1+7}{2}, \frac{1+5}{2}\right) = (4, 3)$ 1

(ii) $AC = \sqrt{(7-1)^2 + (5-1)^2} = 2\sqrt{13}$ 1

(iii) (a) $AB = \sqrt{(7-1)^2 + (1-1)^2} = 6$ $\frac{1}{2}$

$BC = \sqrt{(7-1)^2 + (5-1)^2} = 4$ $\frac{1}{2}$

Area (ABCD) = $AB \times BC = 6 \times 4 = 24$ 1

OR

(iii) (b) $AB = \sqrt{(7-1)^2 + (1-1)^2} = 6$ 1

$$\frac{AB}{AC} = \frac{6}{2\sqrt{13}} = \frac{3}{\sqrt{13}} \quad 1$$

\therefore required ratio is $3 : \sqrt{13}$
